

LI: to use ratio language.

Underline your  
date and LI

### Key vocabulary

relationship, additive, multiplicative,  
sequence, proportion, in every, for every,  
to every, as many as

one digit  
per box

## Our Learning Journey

Step 1 Add or multiply?

Step 2 Use ratio language

Step 3 Introduction to the ratio symbol

Step 4 Ratio and fractions

Step 5 Scale drawing

Step 6 Use scale factors

Step 7 Similar shapes

Step 8 Ratio problems

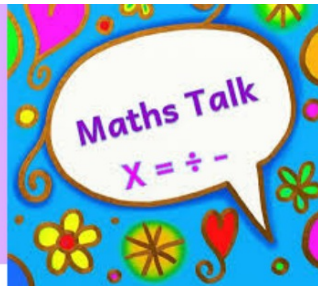

- How can you give the relationship between the number of \_\_\_\_\_ and the number of \_\_\_\_\_?
- For every \_\_\_\_\_, how many \_\_\_\_\_ are there?
- How can you rearrange the counters to make the ratio simpler?
- What number is a common factor of \_\_\_\_\_ and \_\_\_\_\_?  
How can you use this to make the ratio simpler?
- How many \_\_\_\_\_ would there be if there were \_\_\_\_\_?

# Starter/Recap

## Flashback 4

Year 6 | Week 1 | Day 2

White Rose  
MATHS

1) 3, 15, 75,

2) 5 miles  $\approx$  8 km so  miles  $\approx$  48 km

3) Write A and B as fractions in their simplest form.

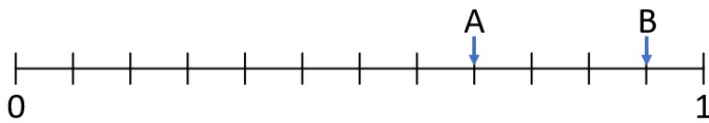

4) Which numbers are divisible by 3?

74	1,044	444,213	708,807
----	-------	---------	---------



## Challenge:

1. What temperature is 4°C cooler than 1°C?

2.   $\div$  4 = 3  $\times$  4 = 60 -

3. How many 12-man tents are needed for 897 people?

4.  $\frac{6}{11} + \frac{1}{4}$

5.  $3 \div 5 = \frac{\text{input}}{\text{input}} = 0.6$

6. I'm training for a race. Round 3,145 m to the nearest km.

# Starter/Recap

## Flashback 4

Year 6 | Week 1 | Day 2

White Rose  
MATHS

1) 3, 15, 75,  $\boxed{375}$

2) 5 miles  $\approx$  8 km so  $\boxed{30}$  miles  $\approx$  48 km

3) Write A and B as fractions in their simplest form.

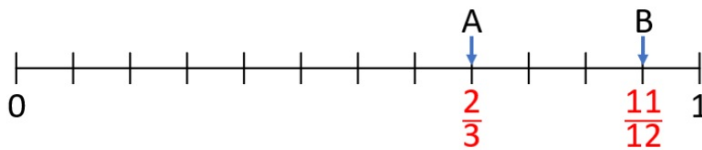

4) Which numbers are divisible by 3?

74	$\boxed{1,044}$	$\boxed{444,213}$	$\boxed{708,807}$
----	-----------------	-------------------	-------------------



# Challenge:

1. What temperature is  $4^{\circ}\text{C}$  cooler than  $1^{\circ}\text{C}$ ?  $-3^{\circ}\text{C}$

2.  $\boxed{48} \div 4 = 3 \times 4 = 60 - \boxed{48}$

3. How many 12-man tents are needed for 897 people?  $75$

4.  $\frac{6}{11} + \frac{1}{4} = \frac{35}{44}$

5.  $3 \div 5 = \frac{\boxed{3}}{\boxed{5}} = 0.6$

6. I'm training for a race. Round 3,145 m to the nearest km.  $3 \text{ km}$

# Assessment

1) For every 6 green sweets, there are \_\_\_\_ red sweets.

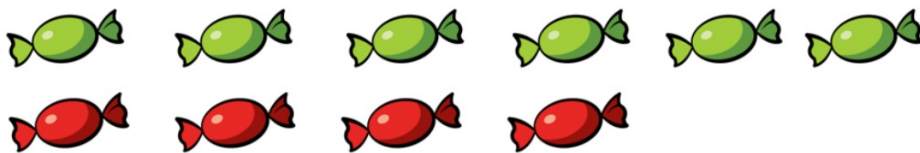

2) How many red cubes altogether?  
 How many green cubes altogether?  
 How many red cubes in each row?  
 How many green cubes in each row?

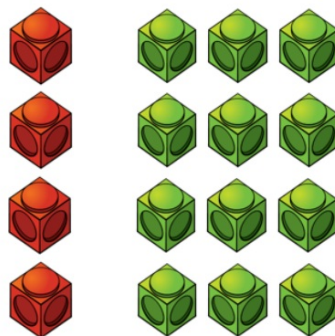

# Challenge:

9a. Tick the statement which is correct.



- A. If there are 9 triangles, there will be 12 squares and 15 hearts.
- B. If there are 6 triangles, there will be 8 squares and 10 hearts.
- C. If there is 1 triangle, there will be 1 square and 2 hearts.

10a. True or false?



If there are 24 lemons, there will be 64 oranges and 32 raspberries.

11a. Complete the sentence below.



If there are 12 pentagons, there will be \_\_\_\_\_ triangles.

12a. Fill in the missing numbers.



If there is 1 , there will be  and  .

If there are 8 , there will be  and  .

# Assessment

1) For every 6 green sweets, there are 4 red sweets.

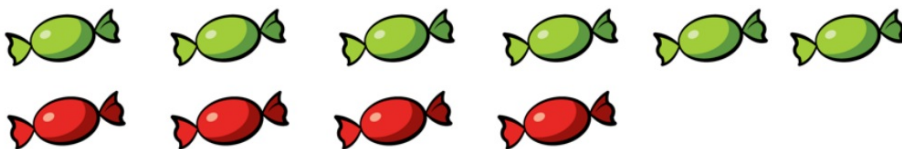

2) How many red cubes altogether? 4

How many green cubes altogether? 12

How many red cubes in each row? 1

How many green cubes in each row? 3

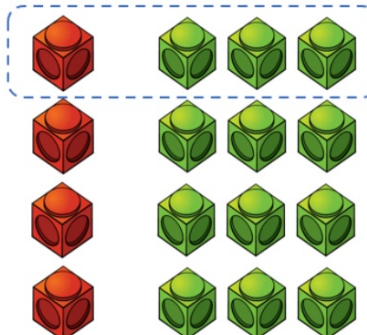

# Challenge:

9a. Tick the statement which is correct.



A. If there are 9 triangles, there will be 12 squares and 15 hearts.

B. If there are 6 triangles, there will be 8 squares and 10 hearts.

C. If there is 1 triangle, there will be 1 square and 2 hearts.

9a. **A and C**

10a. **True**

11a. **9**

12a. **2, 2;**

10a. True or false?



If there are 24 lemons, there will be 64 oranges and 32 raspberries.

11a. Complete the sentence below.



If there are 12 pentagons, there will be \_\_\_\_\_ triangles.

12a. Fill in the missing numbers.



If there is 1 ■, there will be  ▲ and  ●.

If there are 8 ■, there will be  ▲ and  ●.

# Learning Intention: To use ratio language

I do:

Describe the items using the sentence stems.



a For every \_\_\_\_\_ strawberries there are \_\_\_\_\_ bananas.

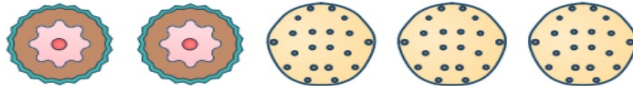

b For every \_\_\_\_\_ cupcakes there are \_\_\_\_\_ cookies.



c For every \_\_\_\_\_ apples there are \_\_\_\_\_ gingerbread men.



d For every \_\_\_\_\_ sandwiches there are \_\_\_\_\_ ice creams.



sequence  
ratio  
for every

**We do:**

## Learning Intention: To use ratio language

- 1) For every 6 green sweets, there are 4 red sweets.

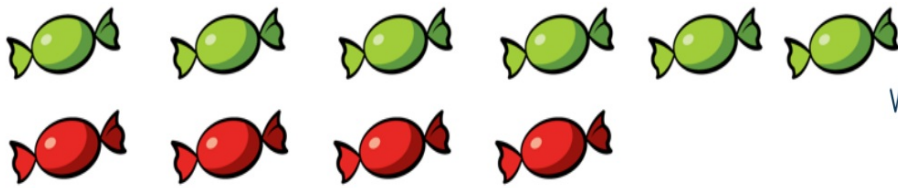

- 2) How many red cubes altogether?  
How many green cubes altogether?  
How many red cubes in each row?  
How many green cubes

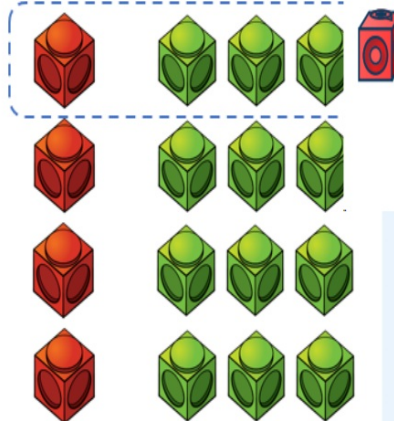

## Challenge

Write sentences to describe the cubes.

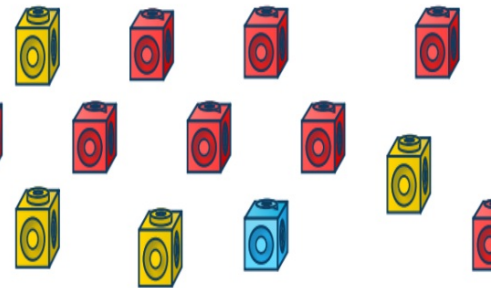

We do:

## Learning Intention: To use ratio language

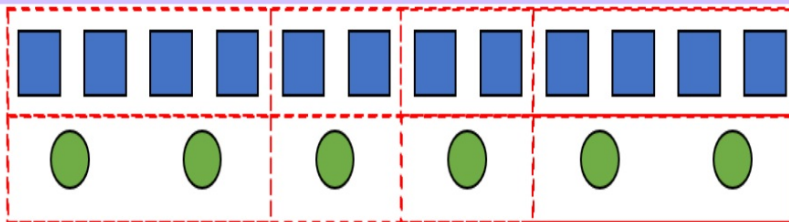

For every 12 squares, there are \_\_\_\_\_ circles.

↓ ÷ 2

For every 6 squares, there are \_\_\_\_\_ circles.

↓ ÷ 2

For every 2 circles, there are \_\_\_\_\_ squares.

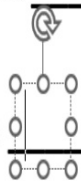

## Challenge

For every red cube, there are 3 green cubes.



If I have 12 green cubes, how many red cubes will there be?

# Task 1 Learning Intention: To You do use ratio language

- Complete the sentences to describe the counters.

There are \_\_\_\_\_ red counters and  
\_\_\_\_\_ yellow counters.

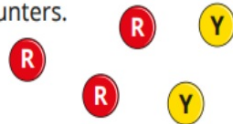

For every \_\_\_\_\_ red counters, there are \_\_\_\_\_ yellow counters.

For every \_\_\_\_\_ yellow counters, there are \_\_\_\_\_ red counters.

- Complete the sentences to describe the cubes.



For every 16 yellow cubes, there are \_\_\_\_\_ blue cubes.

For every 8 yellow cubes, there are \_\_\_\_\_ blue cubes.

For every 1 blue cube, there are \_\_\_\_\_ yellow cubes.

## Task 2

- Amir is using a double number line to find equivalent ratios.

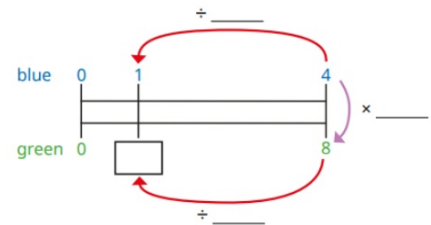

- Use Amir's number line to help you complete the sentence.  
For every 1 blue counter, there are \_\_\_\_\_ green counters.
- Use a double number line to complete the sentences.  
For every 4 green counters, there are \_\_\_\_\_ blue counters.  
For every \_\_\_\_\_ blue counters, there are 16 green counters.

## Extra challenge

- Complete the sentences to describe the fruit.



For every \_\_\_\_\_ pears, there are \_\_\_\_\_ bananas.

For every \_\_\_\_\_ pears, there are \_\_\_\_\_ apples.

Task 3:

We do

Reasoning

Learning Intention: To

use ratio language

You do:

Jack puts red and yellow tiles in this pattern.



I have 16 more red tiles and 20 more yellow tiles.

Can Jack continue this pattern without there being any tiles left over?

Explain your answer.



Decide if each statement is true or false.

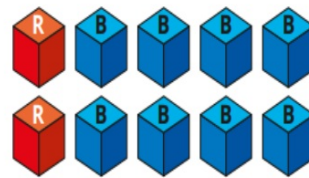

For every red cube, there are 8 blue cubes.

For every 4 blue cubes, there is 1 red cube.

For every 3 red cubes, there would be 12 blue cubes.

For every 16 cubes, 4 would be red and 12 would be blue.

Give reasons for your answers.





## Reflection

1. Callum visited the zoo and created three different statements about the number of animals he saw.

For each lion, there were more than twice as many giraffes.  
For each giraffe, there were 2 toucans.  
There was an even amount of elephants.  
Altogether, I saw 50 animals.



:	:	:
:	:	:
:	:	:



How many of each animal could there have been?  
Create 3 different ratios.

How would you go about solving this question?  
What steps would you use?



LI: to introduce the ratio symbol.

Underline your date and LI

### Key vocabulary

relationship, additive, multiplicative, sequence, proportion, in every, for every, to every, as many as, symbol

one digit per box

### Our Learning Journey

Step 1 Add or multiply?

Step 2 Use ratio language

Step 3 Introduction to the ratio symbol

Step 4 Ratio and fractions

Step 5 Scale drawing

Step 6 Use scale factors

Step 7 Similar shapes

Step 8 Ratio problems

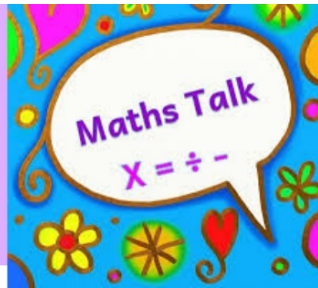

- If there are 3 blue counters and 5 red counters, how can you describe the relationship between these numbers?
- What does the : symbol mean in the context of ratio?
- What does 2 : 3 mean?
- How can you compare the relationship between three quantities?
- Are the ratios 2 : 3 and 3 : 2 the same?
- How else can you write the ratio 2 : 4?

# Starter/Recap

## Flashback 4

Year 6 | Week 1 | Day 3

White Rose  
MATHS

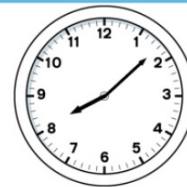

- 1) For every 5 red counters, there are  yellow counters.
- 2) 1 foot = 12 inches, so 84 inches =  feet.
- 3)  $\frac{5}{6} - \frac{6}{8} =$
- 4) Round 7,530,000 to the nearest hundred thousand.

## Challenge:

1. I dive 11 m, rise 5 m, and descend 8 m. What is my current depth?
2.  $\square \div \square = \square \times \square$   
What amount did I save each month if I save £642 in a year?
3.  $\frac{1}{4} + \frac{3}{8} + \frac{1}{5}$
4.  $3 \div \square = \frac{\square}{\square} = 0.75$
5. I'm making a cake.  
6. Round 0.869 kg to the nearest 100 g.

# Starter/Recap

## Flashback 4

Year 6 | Week 1 | Day 3

White Rose  
MATHS

- 1)  For every 5 red counters, there are  yellow counters.



- 2) 1 foot = 12 inches, so 84 inches =  feet.

- 3)  $\frac{5}{6} - \frac{6}{8} = \frac{4}{48}$  or  $\frac{2}{24}$  or  $\frac{1}{12}$

- 4) Round 7,530,000 to the nearest hundred thousand.  
**7,500,000**

## Challenge:

1. I dive 11 m, rise 5 m, and descend 8 m. What is my current depth? **-14 m**

2.   $\div$   =   $\times$

3. What amount did I save each month if I saved £642 in a year? **£53.50**

4.  $\frac{1}{4} + \frac{3}{8} + \frac{1}{5} = \frac{33}{40}$

5.  $3 \div \frac{4}{3} = \frac{3}{4} = 0.75$

- I'm making a cake.  
6. Round 0.869 kg to the nearest 100 g. **900 g**

\*Various answers, one example given

# Assessment

1) For every 8 green sweets, there are \_\_\_\_ red sweets.

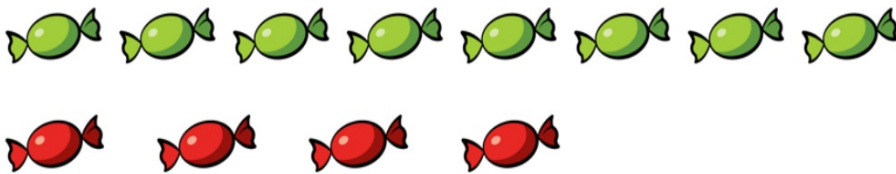

For every 4 green sweets, there are \_\_\_\_ red sweets.

2) For every 3 spiders, there are \_\_\_\_ bees.



For every 3 bees, there is \_\_\_\_ spider.



# Challenge:

10b. Match the statements that mean the same thing.

A. 3:5:1 teas to coffees to hot chocolates

B. 1:4:5 teas to coffees to hot chocolates

C. 5:1:3 hot chocolates to teas to coffees

1. For every tea, there are 5 hot chocolates and 4 coffees.

2. For every tea, there are 5 hot chocolates and 3 coffees.

3. For every hot chocolate, there are 3 teas and 5 coffees.

☆ VF

11b. Write a statement to describe the ratio of 4:1:3 shown below.



☆ VF

12b. Circle the odd one out by matching the ratios to the description.



3:2:1

2:3:1

1:3

cars to buses

buses to lorries to cars

# Assessment

1) For every 8 green sweets, there are 4 red sweets.

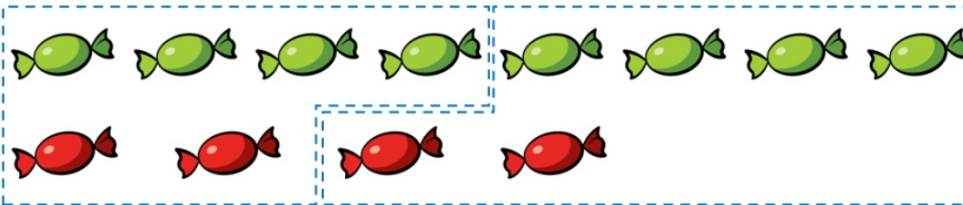

For every 4 green sweets, there are 2 red sweets.

2) For every 3 spiders, there are 9 bees.

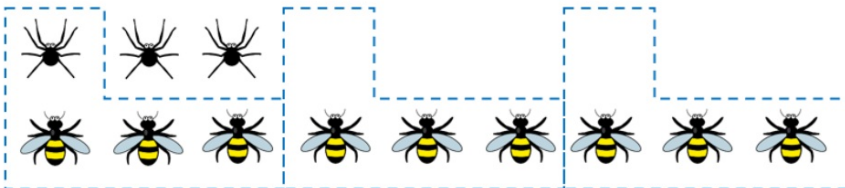

For every 3 bees, there is 1 spider.



## Challenge:

10b. Match the statements that mean the same thing.

A. 3:5:1 teas to coffees to hot chocolates

B. 1:4:5 teas to coffees to hot chocolates

C. 5:1:3 hot chocolates to teas to coffees

1. For every tea, there are 5 hot chocolates and 4 coffees.

2. For every tea, there are 5 hot chocolates and 4 coffees.

10b. A: 3; B: 1; C: 2  
11b. For every 4 giraffes and 3 elephants, there are 5 hot chocolates.  
12b. 2:3:1 is the odd one out.  
3 teas and 5 coffees.



11b. Write a statement to describe the ratio of 4:1:3 shown below.



12b. Circle the odd one out by matching the ratios to the description.



3:2:1

2:3:1

1:3

cars to buses

buses to lorries to cars

## I do

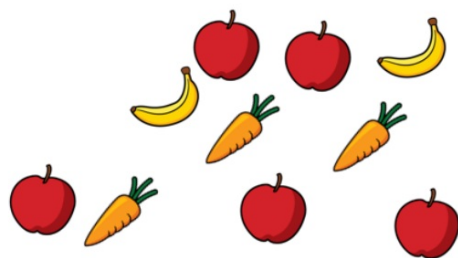

The ratio of carrots to apples is  :

The ratio of apples to bananas is  :

The ratio of carrots to bananas is  :

The ratio of carrots to apples to bananas is  :  :

## We do

## Challenge



Each boat fits 4 people.

The ratio of boats to people is  :

Look at these pictures.

Is it still true that for every boat, there are 4 people?

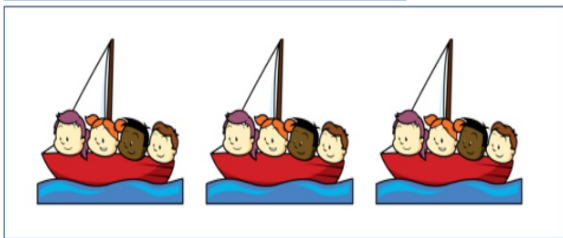
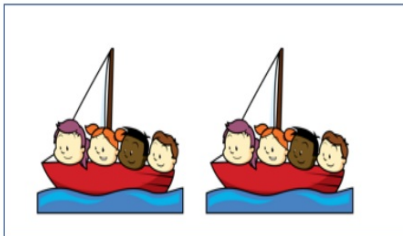

Have a think



Write the ratio of:



- a The circles to triangles
- b The squares to circles
- c The triangles to squares
- d The triangles to circles
- e The circles to squares
- f The squares to triangles

## Task 1:

### You do

- Complete the sentences.



For every \_\_\_\_\_ red counters, there are \_\_\_\_\_ blue counters.

The ratio of red counters to blue counters is \_\_\_\_\_ : \_\_\_\_\_

For every \_\_\_\_\_ blue counters, there are \_\_\_\_\_ red counters.

The ratio of blue counters to red counters is \_\_\_\_\_ : \_\_\_\_\_

- Aisha draws a bar model to show the ratio of yellow to purple gummy bears.



yellow 

purple 

Complete the sentences.

The ratio of yellow gummy bears to purple gummy bears is \_\_\_\_\_ : \_\_\_\_\_

The ratio of purple gummy bears to yellow gummy bears is \_\_\_\_\_ : \_\_\_\_\_

## Task 2:

- Write the ratio of:

- bananas to strawberries
- cherries to strawberries
- strawberries to bananas to cherries
- cherries to strawberries to bananas



Draw a bar model to represent each ratio.

- Here are 8 red counters.



How many blue counters does he need so that the ratio of red to blue is 4 : 5?

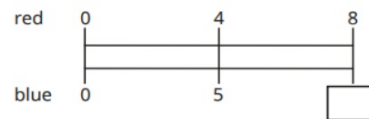

How does the double number line help to work it out?

## challenge

- Max has blue and red counters in the ratio 3 : 5  
He has 15 blue counters.  
How many red counters does he have?

# Task 3: Reasoning We do

# you do



Decide if each statement is true or false.

There are 2 yellow tins for every 3 red tins.

There are 2 red tins for every 3 yellow tins.

The ratio of red tins to yellow tins is 2:3

The ratio of yellow tins to red tins is 2:3

Explain your answers.



In a box, there are some red, blue and green pens.

The ratio of red pens to green pens is 3:5



For every 1 red pen, there are 2 blue pens.



There are 6 red pens in the box.

How many green pens are there?

How many blue pens are there?

Write the ratio of red pens to blue pens to green pens.





## Reflection

2. You have just been awarded £100 to plan a dream day out! You must spend all of your winnings in the following 3 categories: activities, food and travel. You must organise your spending in a ratio of 1 : 2 : 5 between the three categories.

Activities	
Go Gorilla	£25
Wet World	£12.50
Paintball	£15
Go Karting	£10

Food	
Hot dog	£10
Pizza	£15
Burgers	£12.50
Cakes	£15

Travel	
Train	£30
Bike Hire	£12.50
Boat Trip	£32.50
Bus	£25

Explore the possible ways you could spend your £100.

How would you go about solving this question?  
What steps would you use?



LI: to compare ratio and fractions.

Underline your date and LI

### Key vocabulary

relationship, additive, multiplicative, sequence, proportion, in every, for every, to every, as many as, symbol

one digit per box

### Our Learning Journey

- Step 1 Add or multiply?
- Step 2 Use ratio language
- Step 3 Introduction to the ratio symbol
- Step 4 **Ratio and fractions**
- Step 5 Scale drawing
- Step 6 Use scale factors
- Step 7 Similar shapes
- Step 8 Ratio problems

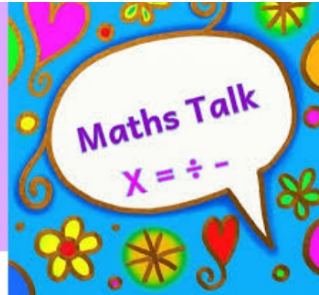

- What is the ratio of one part to another?
- How many parts are there altogether?
- What fraction of the whole is the first/second/third part?
- How are fractions and ratios similar? How are they different?
- What fraction does the ratio 1 : 2 mean? Is this the same as  $\frac{1}{2}$  or is it different?
- How can you represent the ratio/fraction as a bar model?

# Starter/Recap

## Flashback 4

Year 6 | Week 1 | Day 5



1) Represent the ratio 1 : 4 as a bar model.

2) Look at the ratio of yellow counters to green counters.

If there were 8 yellow counters, there would be  green counters.



3)  $\frac{8}{5} \div 2 =$

4)  $7^2 + 2^3 =$



Activate

## Challenge:

1. What is 12 more than -7?

2.  $5 \times 4 +$    $= 80$

3.  $2,030 \div 15$

4.  $\frac{7}{8} - \frac{1}{4}$

5.  $1 \div 4 =$    $= 0.25$

Round the answer to 1

6. decimal place:  
 $3.43 \times 2$

# Starter/Recap

Flashback 4

Year 6 | Week 1 | Day 5

White Rose  
MATHS

- 1) Represent the ratio 1 : 4 as a bar model.



- 2) Look at the ratio of yellow counters to green counters.

If there were 8 yellow counters, there would be  green counters.



3)  $\frac{8}{5} \div 2 = \frac{4}{5}$

4)  $7^2 + 2^3 = 57$

# Challenge:

1. What is 12 more than -7

2.  $5 \times 4 + \text{$  = 80

3.  $2,030 \div 15 = 135 \text{ r}5$

4.  $\frac{7}{8} - \frac{1}{4} = \frac{5}{8}$

5.  $1 \div 4 = \frac{\text{$ }{

6. Round the answer to 1 decimal place:  
 $3.43 \times 2 = 6.9$

# Assessment

1) What fraction of the bar is shaded?



2) For every \_\_\_\_ shaded parts, there are \_\_\_\_ non-shaded parts



3) What is the ratio of bees to spiders?



# Challenge:

9a. Match the fraction of circles to the correct set of objects.

$$\frac{2}{3}$$

A.



$$\frac{1}{3}$$

B.



$$\frac{1}{4}$$

C.



10a. True or false?

If there are 6 pears and 4 apples for every 5 lemons,  $\frac{2}{5}$  of the fruit are pears.



11a. Complete the sentence below if  $\frac{2}{11}$  are pentagons,  $\frac{3}{11}$  are squares and  $\frac{6}{11}$  are circles.

There are \_\_\_\_ pentagons and \_\_\_\_ circles for every \_\_\_\_ squares.



# Assessment

1) What fraction of the bar is shaded?  $\frac{4}{9}$



2) For every 4 shaded parts, there are 5 non-shaded parts



3) What is the ratio of bees to spiders?

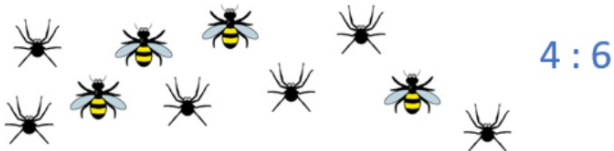

## Challenge:

9a. Match the fraction of circles to the correct set of objects.

$$\frac{2}{3}$$



$$\frac{1}{3}$$



$$\frac{1}{4}$$



9a.  $\frac{2}{3} = C$ ;  $\frac{1}{3} = A$

10a. True

11a.  $\frac{6}{11}$  are squares

pentagons and 3 squares.



10a. True or false?

If there are 6 pears and 4 apples for every 5 lemons,  $\frac{2}{5}$  of the fruit are pears.



11a. Complete the sentence below if  $\frac{2}{11}$  are pentagons,  $\frac{3}{11}$  are squares and  $\frac{6}{11}$  are circles.

There are \_\_\_ pentagons and \_\_\_ circles for every \_\_\_ squares.



## Learning Intention: To compare ratio and fractions

I do:

sequence  
ratio  
for every  
symbol

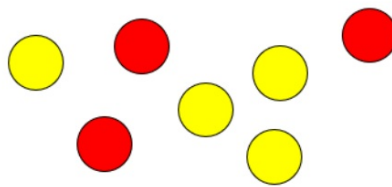

There are \_\_\_ counters altogether.

There are \_\_\_ yellow counters.

There are \_\_\_ red counters.

What fraction of the counters are yellow?

What fraction of the counters are red?

What is the ratio of red to yellow counters?

What is the ratio of yellow to red counters?

What do you notice?

**We do:** Learning Intention: To compare ratio and fractions

Have a think



What fraction of the bar is shaded?

What fraction of the bar not shaded?

Write the ratio of shaded to non-shaded parts.

Write the ratio of non-shaded to shaded parts.

**We do:** Learning Intention: To compare ratio and fractions

Describe the parts of the bar model using fractions.

**a** Striped:   
 Solid:  
 Checked:

**b** Striped:   
 Solid:  
 Checked:

**c** Striped:   
 Solid:  
 Checked:

Use three colours to shade the bar models to show these ratios. Describe the parts using fractions

**d** 3 to 4 to 3 

**e** 2 to 1 to 3 

**f** 7 to 3 to 2 

# Task 1 Learning Intention: To You do compare ratio and fractions Task 2

- The ratio of red counters to blue counters in a box is 1 : 2



- ▶ What fraction of the counters are blue?
- ▶ What fraction of the counters are red?
- ▶ What is the same about the ratio and the fractions? What is different?

- This bar model represents  $\frac{2}{5}$

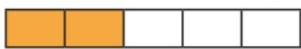

This bar model represents 2 : 5



What is the same and what is different about the bar models?

- Use the diagram to complete the sentences.



The ratio of blue counters to green counters is 2 : \_\_\_\_\_

The fraction of counters that are blue is  $\frac{2}{\square}$

- One third of the chocolates in a box are mint flavoured. The rest are strawberry. Use diagrams to show that the ratio of mint to strawberry chocolates is 1 : 2

- The bar model shows the ratio 2 : 3 : 4



- ▶ What fraction of the bar is pink?
- ▶ What fraction of the bar is yellow?
- ▶ What fraction of the bar is blue?
- Esther gets  $\frac{2}{5}$  of a packet of 30 sweets. Huan shares 70 sweets with his friend in the ratio 2 : 5. How many more sweets does Huan get than Esther?

## Extra challenge

- Brett opens a box of buttons and counts the different colors
  - $\frac{1}{2}$  of them are red.
  - $\frac{1}{3}$  them are green.
  - The rest are yellow.

What is the ratio of red : green : yellow buttons in the box?

Task 3: Learning Intention: To compare fractions and  
Reasoning We do You do:

There are some red and green cubes in a bag.



$\frac{2}{7}$  of the cubes are red.

Are the statements true or false?

For every 2 red cubes, there are 7 green cubes.

For every 2 red cubes, there are 5 green cubes.

For every 5 green cubes, there are 2 red cubes.

For every 5 green cubes, there are 7 red cubes.

Explain your answers.



Mrs Fisher plants flowers in a flower bed.

For every 2 red roses, she plants 3 white roses.

$\frac{2}{3}$  of the roses are red.



Is Tiny correct?

Explain your answer.



Dani makes 240 ml of squash using cordial and water in the ratio 1 : 3



She adds more water to the cup so there is now 300 ml of squash.

What fraction of the drink is cordial?



## Reflection

2. Mr Watkins is organising a school trip.

He says,



The ratio of adults to children for the trip needs to be one adult for every eight children. The maximum number of children who said that they will be going on the trip is a multiple of 8 no more than 125.

The fraction of adults going can always be simplified to one ninth.

Investigate the maximum number of adults that will be needed and whether the statement is true.

How would you go about solving this question?  
What steps would you use?



LI: to understand scale drawings.

Underline your date and LI

### Key vocabulary

relationship, additive, multiplicative, sequence, proportion, in every, for every, to every, as many as, symbol, scale, represent

one digit per box

### Our Learning Journey

- Step 1 Add or multiply?
- Step 2 Use ratio language
- Step 3 Introduction to the ratio symbol
- Step 4 Ratio and fractions
- Step 5 **Scale drawing**
- Step 6 Use scale factors
- Step 7 Similar shapes
- Step 8 Ratio problems

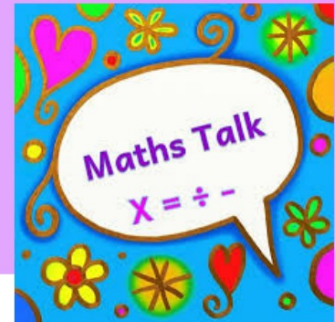

- How do you know if a diagram is drawn to scale?
- Why might you need to draw a scale diagram?
- If 1 square represents 5 cm, what do \_\_\_\_\_ squares represent? How do you know?
- If 1 square represents 5 cm, how many squares represent \_\_\_\_\_ cm? How do you know?
- Is there more than one way of finding the missing value?
- How is a scale like a ratio?

# Starter/Recap

## Flashback 4

Year 6 | Week 2 | Day 1



1) On a scale diagram, 6 cm represents 1 m.  
What does 72 cm represent?

2) Write the ratio of blue to green to yellow.



3) Choose the most appropriate estimate for the mass of a banana.

- 1 g     10 g     100 g     1 kg

4)  $19 \times 472 =$



## Challenge:

1.  $-30 + 48 =$

2.  +  $11 \times 4 = 60$

3,845 items are put into  
3. boxes of 11. How many boxes are needed?

4.  $\frac{5}{6} - \frac{3}{4}$

5.  $1 \div 8 =$   = 0.125

Round the answer to 1 decimal place:  
6.  $6.94 + 3.18$

# Starter/Recap

## Flashback

4

Year 6 | Week 2 | Day 1



1) On a scale diagram, 6 cm represents 1 m.  
What does 72 cm represent? **12 m**

2) Write the ratio of blue to green to yellow.

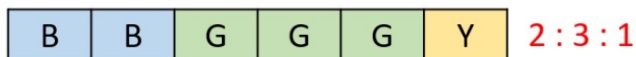

3) Choose the most appropriate estimate for the mass of a banana.

1 g     10 g     100 g     1 kg

4)  $19 \times 472 =$  **8,968**



# Challenge:

1.  $-30 + 48 = 18$

2.  +  $11 \times 4 = 60$

3,845 items are put into  
3. boxes of 11. How many  
boxes are needed? **350**

4.  $\frac{5}{6} - \frac{3}{4} = \frac{1}{12}$

5.  $1 \div 8 = \frac{\text{input}}{8} = 0.125$

Round the answer to 1  
6. decimal place:  
 $6.94 + 3.18 = 10.1$

# Assessment

1)  $30 \div \underline{\quad} = 5$

2) If 1 square represents 5 cm, how many squares represent 30 cm?

3) If 1 square represents 4 m, how many squares represent 48 m?

4) What is half of 15?



# Challenge:

1a. Look at the shape below.

Tick the shapes that are not scale drawings of the original.

A.

B.

C.

D.

2a. Complete the statements for the images below.

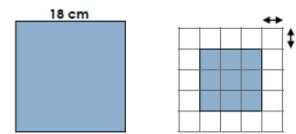

$18 \div \square = 3$  small squares

One small square represents     cm.

3a. Here is a rectangle. Draw a scale diagram on the grid below.

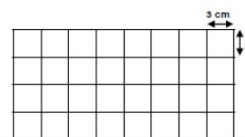
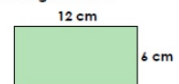

# Assessment

1)  $30 \div \underline{6} = 5$

2) If 1 square represents 5 cm, how many squares represent 30 cm? **6 squares**

3) If 1 square represents 4 m, how many squares represent 48 m? **12 squares**

4) What is half of 15? **7.5**



## Challenge:

1a. Look at the shape below.

Tick the shapes that are not scale drawings of the original.

1a. A and B are not scale drawings  
 1b. A and C are not scale drawings  
 2a.  $18 \div 6 = 3$  small squares  
 One small square represents 6 cm  
 2b.  $10 \div 5 = 2$  small squares  
 One small square represents 5 cm  
 3a.

2a. Complete the statement: images below.

$18 \div \square = 3$  small squares  
 One small square represents 6 cm.

3b.

3a. Here is a rectangle. Draw a scale diagram on the grid below.

# I do:

1 Each small square has side lengths of 4cm. Draw squares which have sides with the following lengths:

- a 16cm
- b 20cm
- c 48cm
- d 8cm
- e 28cm
- f 40cm

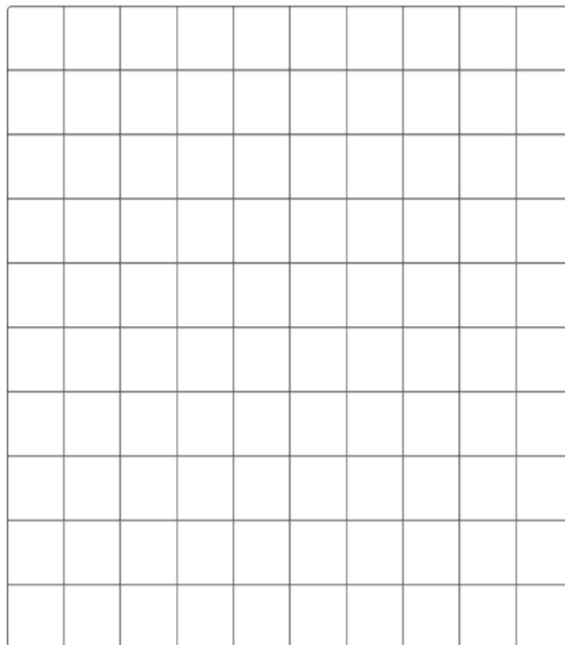

scale  
represent

## We do:

A swimming pool is 10m by 4m. Draw a scale diagram where each square represents 2m.

scale  
represent

## Challenge

On a scale diagram, 4cm represents 1m.  
What does 8cm represent?  
What does 40cm represent?  
What does 2cm represent?  
What does 1cm represent?  
What length in cm would represent 3m?

# Task 1

## You do

# Task 2:

- A square has side lengths of 12 cm.

Scott has drawn a scale diagram of the shape in which the side length of each square in the grid represents 2 cm.

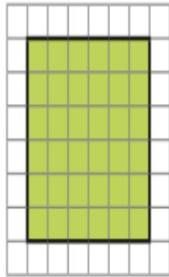

Use squared paper to draw other scale diagrams using the side length of each square to represent:

- 3 cm
- 4 cm
- 6 cm
- 12 cm

- This is a plan of a classroom.

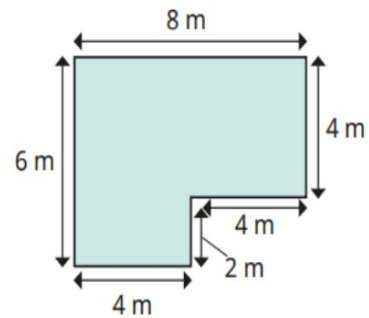

Using squared paper, draw a scale diagram of the classroom if each square on the grid represents 2 m.

- A football pitch measures 48 m by 72 m.  
Using squared paper, draw a scale diagram of the football pitch if each square on the grid represents 8 m.

## Task 3: We do

Tiny wants to draw a scale diagram of this rectangle.

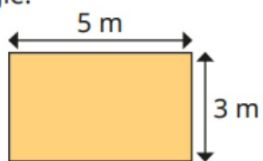

Each square on the grid represents 2 m.

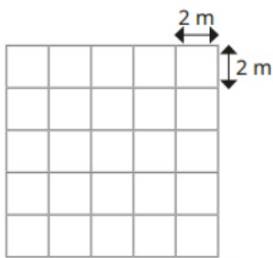

I cannot draw it on this grid, because 3 and 5 are not multiples of 2

Do you agree with Tiny?

Explain your answer.



## You do

Here is a plan of a room.

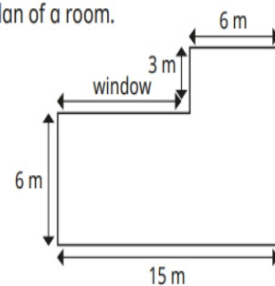

Draw a scale diagram of the room where each square represents 3 m.

What is the actual length of the window?

What is the area, in squares, of the room in the scale diagram?

What is the actual area of the room?

Explain the connection between your answers.

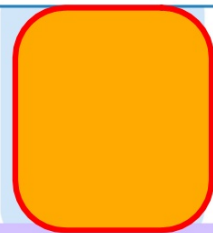

## Plenary:

Two matchsticks have the same length as three bottle tops.

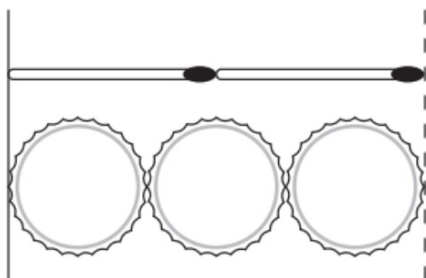

How many bottle tops will have the same length as 50 matchsticks?

A large rectangular grid for writing the answer. The grid is 20 units wide and 10 units high. A small rectangular box is drawn in the bottom right corner of the grid, spanning 5 units in width and 2 units in height, intended for the student to write their answer.

[2 marks]

## Reflection

Investigate and draw possible scaled diagrams for the original shape and information given below. Write the original dimensions and the multiplication or division facts you used to help you scale. Finally, write what each square would represent.

One side is an even number of cm and one side is an odd number of cm.

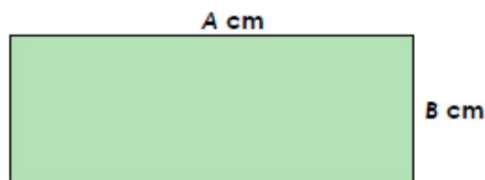

*original shape*

A	A two-digit number $>29$ but $< 50$ .
B	A number between 9 and 30.

How would you go about solving this question?  
What steps would you use?

